

When safety, security and convenience are at stake.

PORTA **WINCH**[™]



PORTA **ANCHOR**[™]

Introducing the newest additions to the Ancra family of cargo restraint systems.

ANCRA
INTERNATIONAL

Now there are two sides to the

PORTAWINCH™

**The Winch That Fits
Where Others Won't**

Why PortaWinch?

Those who have their fingers on the pulse of the trucking industry today know that load securement is a growing concern among flatbedders. Costs associated with longer load tie-down times, potential liability lawsuits, and increased insurance costs are all affecting the bottom line. No good solutions to this growing problem have existed on the market until now. No more bolt-on winches that require drilling and tools. No more inconvenient clamp-on winches that can vibrate loose. No more expensive ratchet tie-down straps that don't adequately secure your load and become tangled in your tool box. And no more worry about DOT delays or fines because of improper load securement. The solution has arrived, and it's right on time. Totally portable. Totally tough. Totally secure.

The Facts

- **Laboratory tested to hold over 17,500 lbs.**
- **Uses standard straps and winch bar**
- **Installs on sides and both ends of trailer**
- **Fits all stake pockets**
- **Works over tires and toolboxes**
- **Installs quickly and easily with no tools**



The PortaWinch installs easily and quickly. The patented spring-loaded front-hook design stays secured in the event of a load shift and distributes the load evenly across the stake pocket.



The PortaWinch top-loads into any stake pocket on your trailer. It secures your load utilizing your standard 4" strap and winch bar.



The PortaWinch cap has four winch bar holes to allow you to tighten the straps in tight spaces.

PortaWinch Specifications

- Working load limit (WLL) – 5,500 lbs.
- Maximum strap width – 4 inches
- SPF features standard outward off-set
- SPC features inward off-set to allow for track-mounted tarp clearance

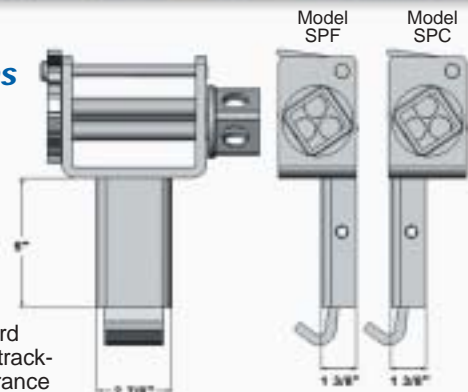

The load-securement equation

PORTAANCHOR™

Turns Any Stake Pocket Into An
FMCSA Compliant Anchor Point



Why PortaAnchor?

Convenience. Safety. New DOT regulations. There are many reasons to make the PortaAnchor a permanent load securement tool in your tool box. The rub rail has long provided a convenient anchor point for securement straps. As of January 2004, the DOT has enforced new securement regulations that make it illegal to hook securement straps to the rub rail under normal conditions. The PortaAnchor offers the perfect alternative to the rub rail. First, the PortaAnchor secures to the stake pocket, a legal securement point. Second, it offers the same safe securement as the rub rail, because the securement hook hangs from the PortaAnchor in the same way it hangs on the rub rail. To avoid the inconvenience of inspections and fines, you need the PortaAnchor.

The Facts

- Allows you to anchor straps securely and legally
- Accepts standard 4 inch straps and chains
- Installs on sides and both ends of the trailer
- Fits all stake pockets
- Works over tires and toolboxes
- Installs quickly and easily with no tools

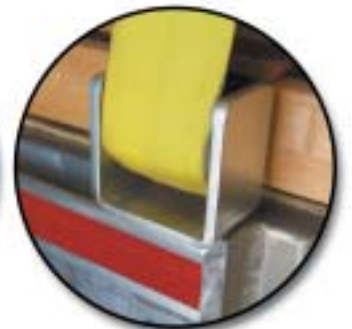
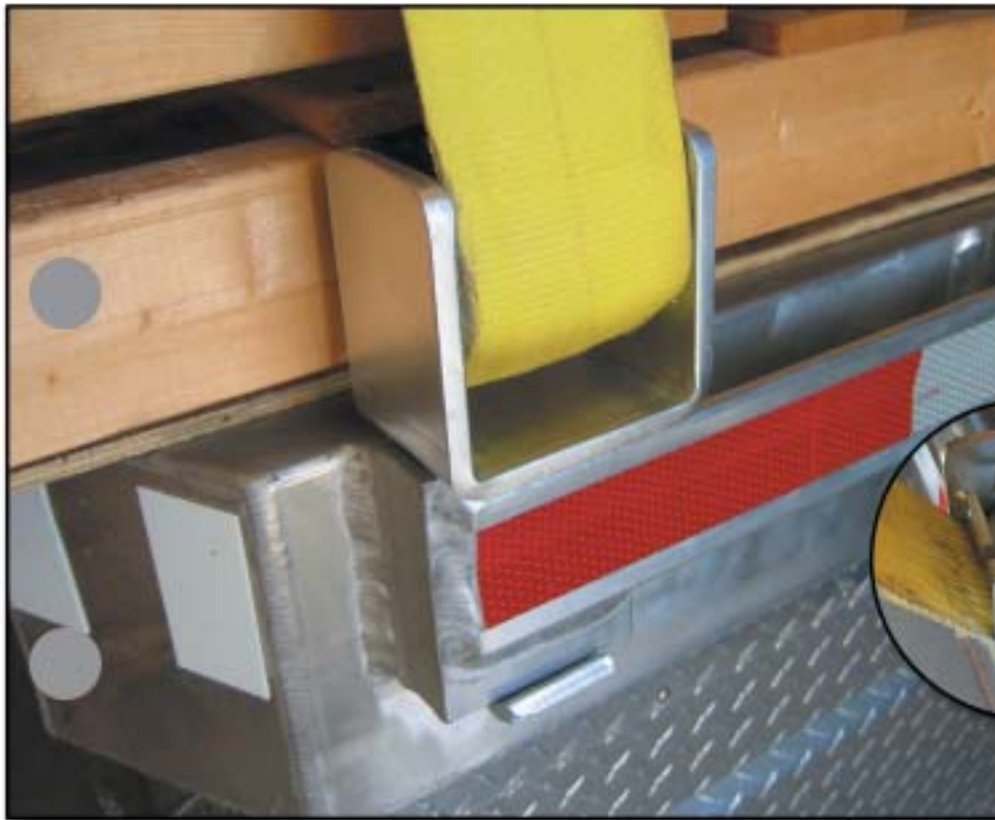

The PortaAnchor works with all your standard flat-hook cargo restraint straps - up to 4 inches wide.

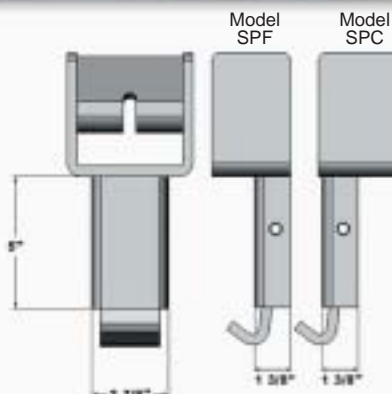

PortaAnchor Specifications

- Working load limit (WLL) – 5,500 lbs.
- Maximum strap width – 4 inches
- SPF features standard outward off-set
- SPC features inward off-set to allow for track-mounted tarp clearance

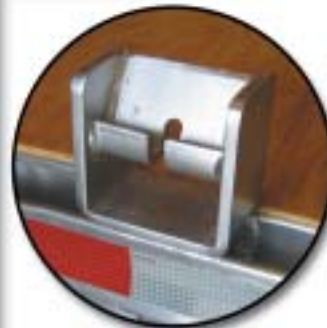

The PortaAnchor is robust in design and construction. It works with the PortaWinch or any other winch or ratchet buckle system.

The PortaAnchor also accepts chain and hook load assemblies as well as web-straps with chain anchors or wire hooks.



Designers and Manufacturers
of Cargo Restraint Systems

Since 1969 Ancra International has been a world-class designer and manufacturer of restraint-related components and assemblies serving the commercial vehicle market and other industries. Ancra's product line is based on more than a quarter century of cargo restraint experience, including 49 patents and 43 product trademarks. Each product is made from only the finest materials with attention given to every engineering detail. All component parts and materials are selected for performance and durability to offer customers the most cost-effective and reliable cargo restraint systems available. Ancra International. There's strength in the name!

ANCRA SIGNATURE PRODUCTS - Innovations in cargo restraint



GLIDELOCK™
Sliding Load-Securement Bracket

FMCSA Compliant Load Securement Bracket

Easy to use GlideLock brackets slide into place wherever you need them on your trailer rail or winch track, allowing you to safely and legally secure your cargo using any standard flat-hook tiedown strap. GlideLock's patented design is compliant with FMCSA regulations.



Ancra BLUE Cargo Restraint Straps

The ultimate in webbing strength and performance

Ancra BLUE 24,000 lb. webbing, dramatically improves facial abrasion resistance and gives webbing more body and firmness. Ancra BLUE also delivers 70% retained strength after 2,500 full cycles for an unparalleled durability rating. Available with flat-hooks, delta rings, half-twist loops and chain anchors.



SilverCap
The World's First Ratcheting Winch

The world's first ratcheting winch

SilverCap is the most significant improvement to the winch since the invention of the winch. SilverCap's patented ratcheting action allows you to keep the winch-bar in the cap until the load strap is tightened, reducing the chance of bar slipping or jamming. Available in weld-on, sliding and portable models.



Torque Limiting Ratchet Buckle

Maximum tension without damage

Damaged logistic track or buckled sidewalls are a thing of the past with Ancra's Torque Limiting Ratchet Buckle. The patented ratchet mechanism limits tightening torque to 300 ft. lbs. - enough to secure the load, but not enough to cause damage from over tightening. Available individually or as tiedown strap assemblies.



ANCRA INTERNATIONAL
2685 Circleport Drive • Erlanger, Kentucky 41018
800-233-5138 • www.ancra.com

B220 ©Ancra International 2005 Printed in the U.S.A. 8/05